

CDG160D, CDG200D

SKY® Capacitance Diaphragm Gauges

INFICON SKY CDG160D and CDG200D high temperature manometers are your best choice for accurate total pressure measurement and control. CDG160D and CDG200D gauges are temperature controlled at 160 °C respectively 200 °C for superior performance in demanding semiconductor and plasma processes. They are available for full scale ranges from 1 Torr to 1000 Torr, with all common flange types and fieldbus interfaces and provide a linear 0 to 10 V, gas type independent, pressure signal. INFICON capacitance manometers use an ultra pure alumina ceramic diaphragm which is corrosion proof. The advantages of the ceramic sensor are better signal stability, faster recovery from atmosphere, short warm up time and an extraordinary lifetime. INFICON CDG are high quality, cost effective pressure sensors for demanding semiconductor, plasma and vacuum applications.

ADVANTAGES

- Lower CoO (cost of ownership), 50% faster warm up, energy efficient low power consumption
- Easy integration, wide variety of full scales, flanges and interfaces, standard with two set points
- Easy one push button or remote signal zero command, zero offset adjustable
- Diagnostic port for quick service and maintenance
- Two year warranty, longer life time with  heating concept and gauge protection
- No long term recalibration due to excellent signal stability and repeatability, even in harsh plasma applications
- Compliance & standards: CE, EN, UL, SEMI, RoHS

APPLICATIONS

- Etch, CVD, PVD, LPCVD and other semiconductor production processes
- Chemical and corrosive high temperature processes
- General thin film and vacuum processes requiring gauge protection



New
200 °C sensor

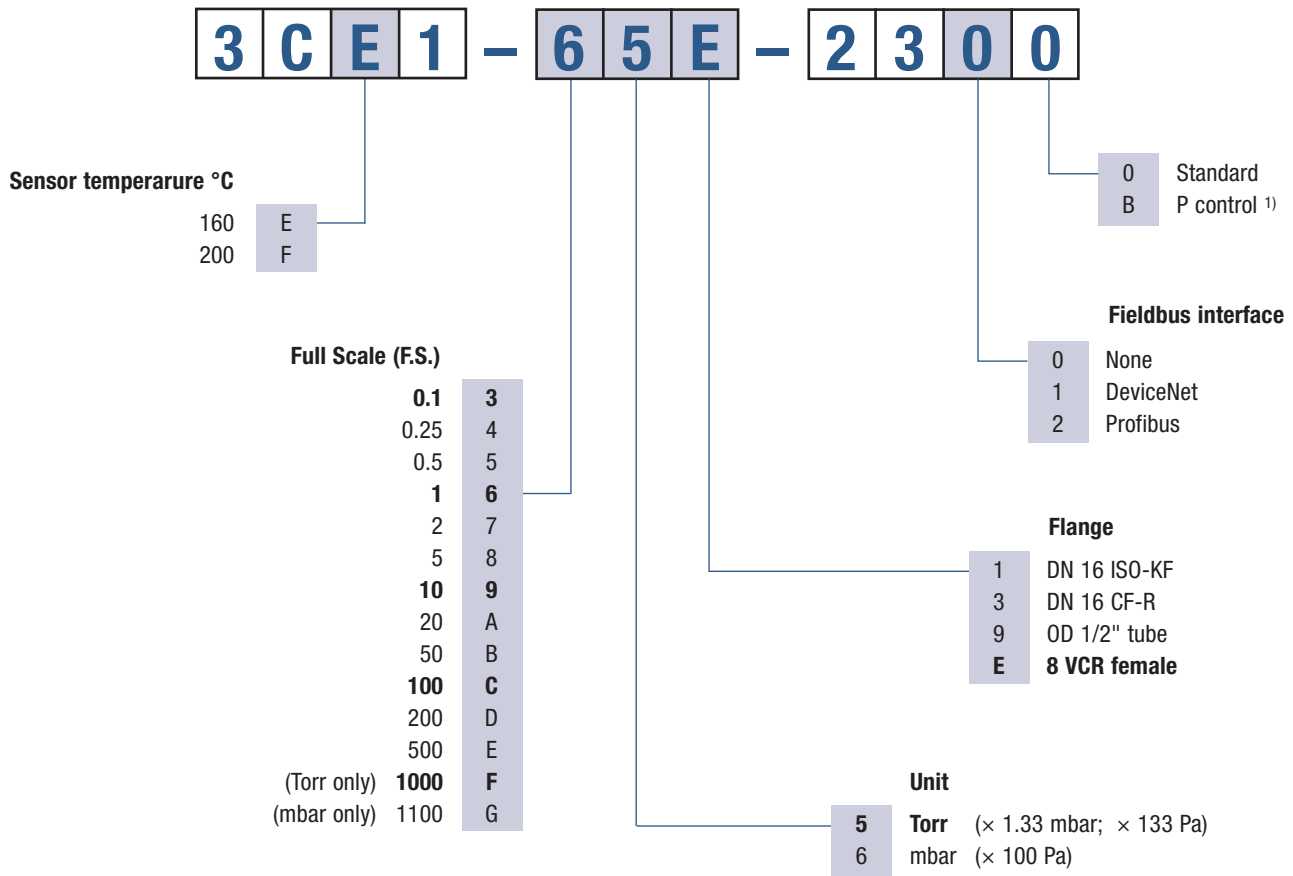

¹⁾ Optimised signal filter setting for pressure control.

bold = standard products

Other flange types and full scale ranges (F.S.) on request.

ACCESSORIES

	Diagnostic
Communication adapter (2 m) for PC RS232 serial port	303-333

Software to run the diagnostic functions on Windows NT, XP can be downloaded from our website.

SPECIFICATIONS (Torr based standard products)

Measurement Range F.S. (Full Scale)	Torr Pa mbar	1000 133'322 1333	100 13'332 133	10 1'333 13.3	1 133 1.3
Accuracy ¹⁾	% of reading	0.4			
Temperature effect on zero	% F.S./°C	0.005			
on span	% of reading/°C	0.02			
Pressure, max.	kPa (absolute)	400	260		
Resolution	% F.S.	0.003			
Lowest reading	% F.S.	0.01			
Lowest suggested reading	% F.S.	0.05			
Lowest suggested control pressure	% F.S.	0.5			
Temperature Operation (ambient)	°C	+10 ... +50			
Bakeout at flange	°C	≤200			
Storage	°C	-40 ... +65			
Supply voltage		+21 ... +30 VDC or ±15 V (±5%)			
Power consumption during heat up CDG160	W	≤18			
CDG200	W	≤25			
Power consumption at operating temperature CDG160	W	≤12			
CDG200	W	≤18			
Output signal (analog)	VDC	0 ... +10			
Response time ²⁾	ms	30			
Degree of protection		IP 40			
Standards		EN 61000-6-2/-6-3, EN 61010, UL 61010-1, CSA 22.2 No.61010-1, SEMI S-2			
Electrical connection		D-sub, 15 pole, male			
Setpoint		two setpoints (SP1, SP2)			
Relay contact	VDC / ADC	≤30 / ≤0.5			
Hysteresis	% F.S.	1			
Diagnostic port Protocol		RS232-C			
Read		pressure, status, ID,			
Set		set points, filter, zero adjust, factory reset, DC offset			
Materials exposed to vacuum		Aluminum oxide ceramic (Al2O3), stainless steel (AISI 316L ³⁾)			

¹⁾ Non-linearity, hysteresis, repeatability at 25 °C ambient operating temperature without temperature effects after 2 hours operation.

²⁾ Increase 10 ... 90% F.S.

³⁾ 18% Cr, 10% Ni, 3% Mo, 69% Fe

SPECIFICATIONS (Torr based other ranges)

Measurement Range F.S. (Full Scale)	Torr Pa mbar	500 66'661 666.61	200 26'664 267	50 6'666.1 66.67	20 2'666 26.7	5 666.61 6.6661	2 266.66 2.67
Accuracy ¹⁾	% of reading	0.4					
Temperature effect on zero	% F.S./°C	0.005					
on span	% of reading/°C	0.02					
Pressure, max.	kPa (absolute)	400	260				
Resolution	% F.S.	0.003					

¹⁾ Non-linearity, hysteresis, repeatability at 25 °C ambient operating temperature without temperature effects after 2 hours operation.

Further specifications see table above.

SPECIFICATIONS (mbar based products)

Measurement Range F.S. (Full Scale)	mbar Pa	1100 110'000	100 10'000	10 1'000	1 100
Accuracy ¹⁾	% of reading	0.4			
Temperature effect on zero	% F.S./°C	0.005			
on span	% of reading/°C	0.02			
Pressure, max.	kPa (absolute)	400	260		
Resolution	% F.S.	0.003			

¹⁾ Non-linearity, hysteresis, repeatability at 25 °C ambient operating temperature without temperature effects after 2 hours operation.
Further specifications see tables «SPECIFICATIONS (Torr based standard products)» and «SPECIFICATIONS (Torr based other products)».

SPECIFICATIONS (DeviceNet™)

			CDG160D, CDG200D DeviceNet™
Protocol			DeviceNet™, group 2 slave only
Data rate	kBaud		125, 250, 500 by switch or network programmable
Cable length			
125 kbps	m (ft)		500 (1650)
250 kbps	m (ft)		250 (825)
500 kbps	m (ft)		100 (330)
MAC ID			address 00 - 63 by switch or network programmable
Digital functions	read		pressure, status, ID
	set		set points, filter, zero adjust, factory reset, DC offset
Specification			DeviceNet™ "Vacuum Gauge Device Profile" (ODVA)
Device type			"VG" vacuum gauge
I / O slave messaging			polling only
Supply voltage for gauge at D-sub connector			+14 ... +30 VDC or ±15 V / ≤12 W
Supply voltage for DeviceNet transceiver at microstyle connector			24 V nom / <2 W (11 ... 25 V)
Connector for DeviceNet™			microstyle, 5 pin, male
Connector for CDG (analog output, supply voltage CDG, setpoints)			D-sub, 15 pin, male

SPECIFICATIONS (Profibus DP)

			CDG160D, CDG200D Profibus DP
Baud rates	kBaud		9.6 / 19.2 / 93.75 / 187.5 / 500
	MBaud		1.5 / 12
Address			address 00 - 125 by switch or network programmable
Digital functions	read		pressure, status, ID
	set		set points, filter, zero adjust, factory reset, DC offset
Connector for Profibus DP			D-sub, 9 pin, female
Connector for CDG (analog output, supply voltage, setpoints)			D-sub, 15 pin, male

DIMENSIONS, INTERNAL VOLUME, WEIGHT

mm (inch)

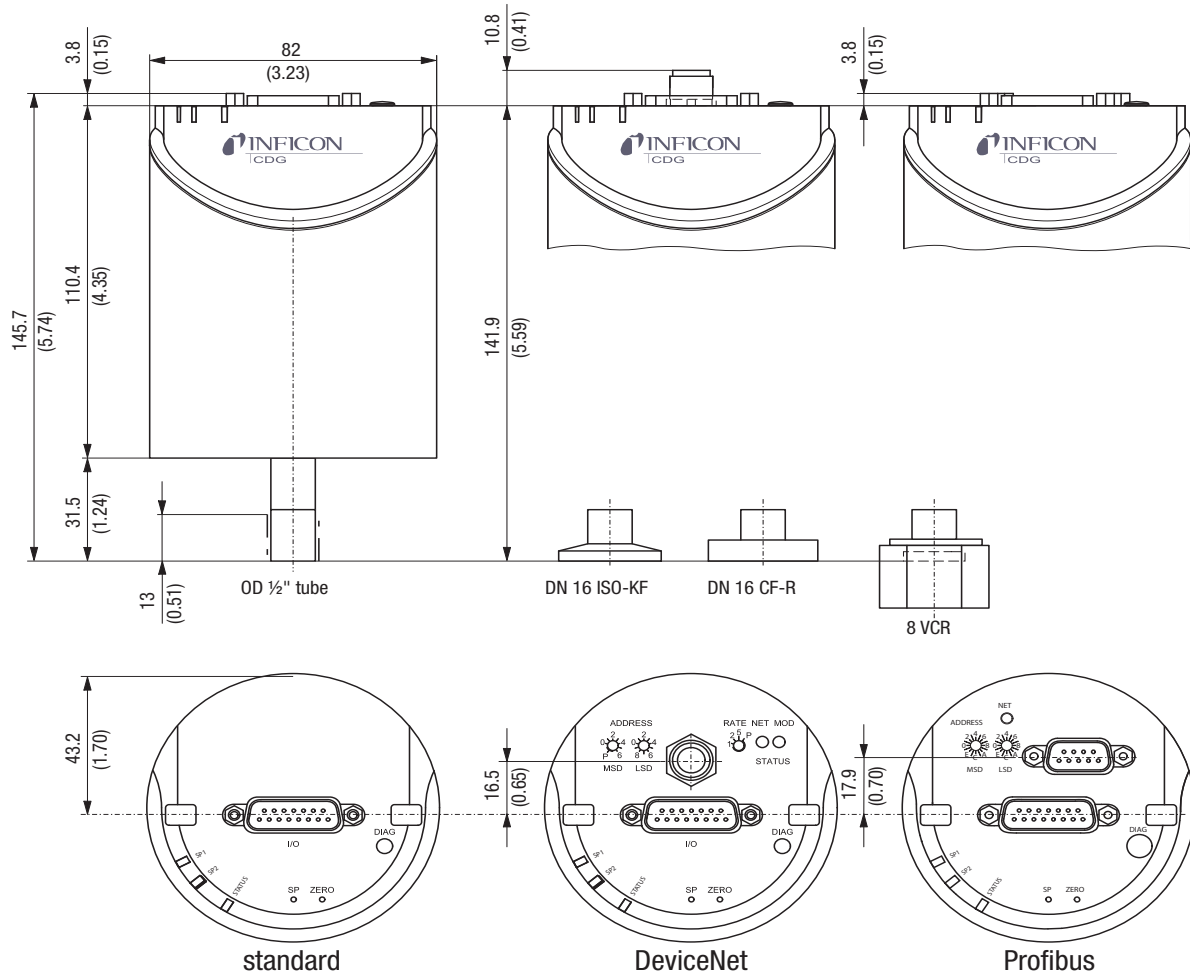

		1/2" tube	DN 16 ISO-KF	DN 16 CF-R	8 VCR®
Internal volume	cm ³ (inch ³)	4.2 (0.26)	4.2 (0.26)	4.2 (0.26)	4.2 (0.26)
Weight	g	837	852	875	897

INFICON Instruments for Intelligent Control®

www.inficon.com reachus@inficon.com

Due to our continuing program of product improvements, specifications are subject to change without notice.

tiba36e1-b (2009-12) ©2009 INFICON